

TECHNISCHE ÄNDERUNGEN VORBEHALTEN · NACHDRUCK UND KOPIEN NUR MIT UNSEREM EINVERSTÄNDNIS · Specifications subject to change without notice · Copyright ELAFLEX

GRUPPE 3 Section	Gewicht Weight Approx. ≈ kg	Abmessungen ≈ mm Dimensions ≈ mm		Form Style	WERKSTOFF Material	GEWINDE- GRÖSSE Thread Size		BESTELL- NUMMER Part Number Type
		d	L			IG	AG	
0,14	18	24	1	Edelstahl 1.4571 GD = PTFE *) stainless steel AISI 316 Ti INOX GD = PTFE *)	G 3/4"	G 1"	RS 3/4 x 1 SS	
0,09	18	28	2		G 1"	G 3/4"	RS 1 x 3/4 SS	
0,14	23	35	1		G 1"	G 1 1/4"	RS 1 x 1 1/4 SS	
0,21	23	26	1		G 1"	G 1 1/2"	RS 1 x 1 1/2 SS	
0,32	24	31	1		G 1"	G 2"	RS 1 x 2 SS	
0,13	24	36	2		G 1 1/4"	G 1"	RS 1 1/4 x 1 SS	
0,22	32	36	1		G 1 1/4"	G 1 1/2"	RS 1 1/4 x 1 1/2 SS	
0,27	32	28	1		G 1 1/4"	G 2"	RS 1 1/4 x 2 SS	
0,23	24	38	2		G 1 1/2"	G 1"	RS 1 1/2 x 1 SS	
0,22	32	40	2		G 1 1/2"	G 1 1/4"	RS 1 1/2 x 1 1/4 SS	
0,21	38	31	1		G 1 1/2"	G 2"	RS 1 1/2 x 2 SS	
0,27	24	38	2		G 2"	G 1"	RS 2 x 1 SS	
0,25	32	40	2		G 2"	G 1 1/4"	RS 2 x 1 1/4 SS	
0,26	38	42	2		G 2"	G 1 1/2"	RS 2 x 1 1/2 SS	
0,40	48	41	1		G 2"	G 2 1/2"	RS 2 x 2 1/2 SS	
0,67	48	42	7		G 2"	G 3"	RS 2 x 3 SS	
0,44	48	47	2		G 2 1/2"	G 2"	RS 2 1/2 x 2 SS	
0,50	63	35	1		G 2 1/2"	G 3"	RS 2 1/2 x 3 SS	
0,53	48	50	2		G 3"	G 2"	RS 3 x 2 SS	
0,56	63	52	2		G 3"	G 2 1/2"	RS 3 x 2 1/2 SS	
1,05	76	36	1	G 3"	G 4"	RS 3 x 4 SS		
3,40	76	82	8	G 3"	5 1/2" 1)	RS 3 x 5 1/2 SS		
0,93	76	56	2	G 4"	G 3"	RS 4 x 3 SS		
2,95	100	86	8	G 4"	5 1/2" 1)	RS 4 x 5 1/2 SS		
0,15	20	30	9	Edelstahl 1.4404 (1.4571, 1.4301) stainless steel AISI 316 L (AISI 316 Ti, AISI 304) GD = PTFE *) KD = NBR blau NBR blue Form 10: Mutter Edelstahl 1.4301 (1.4307) Form 10: Swivel Nut stainless steel AISI 304 (AISI 304 L)	G 3/4"	Rd 44 x 1/6	RS 3/4 x 44 SS	
0,18	25	34	9		G 1"	Rd 52 x 1/6	RS 1 x 52 SS	
0,33	38	40	9		G 1 1/2"	Rd 65 x 1/6	RS 1 1/2 x 65 SS	
0,40	50	45	9		G 2"	Rd 78 x 1/6	RS 2 x 78 SS	
0,83	80	50	9		G 3"	Rd 110 x 1/4	RS 3 x 110 SS	
0,25	20	35	10		Rd 44 x 1/6	G 3/4"	RS 44 x 3/4 SS	
0,30	25	40	10		Rd 52 x 1/6	G 1"	RS 52 x 1 SS	
0,35	38	45	10		Rd 65 x 1/6	G 1 1/2"	RS 65 x 1 1/2 SS	
0,45	50	50	10		Rd 78 x 1/6	G 2"	RS 78 x 2 SS	
0,90	80	60	10		Rd 110 x 1/4	G 3"	RS 110 x 3 SS	

Dichtungen **GD** sind auch aus Polyurethan oder asbestfreiem THERMOPAC (HBD) lieferbar
*) Upon request thread seals **GD** can be supplied in polyurethane or asbestos-free THERMOPAC



Reduzierstücke Type **RS**, einerseits Rohr-Innengewinde mit einliegender Gewindedichtung GD, andererseits Rohr-Außengewinde, flachdichtend mit stirnseitiger Dichtfläche. (G = DIN EN ISO 228). - Die Gewindelängen entsprechen den Mindestlängen der jeweiligen Gewindenorm und Gewindegröße.

Female/male reducers type **RS**, one end female pipe thread with captive seal GD, other end male pipe thread, with flat sealing surfaces. (G = thread acc. to DIN EN ISO 228 / BSP parallel). - The thread lengths are according to the minimum lengths of the thread standards and sizes.



Type RS

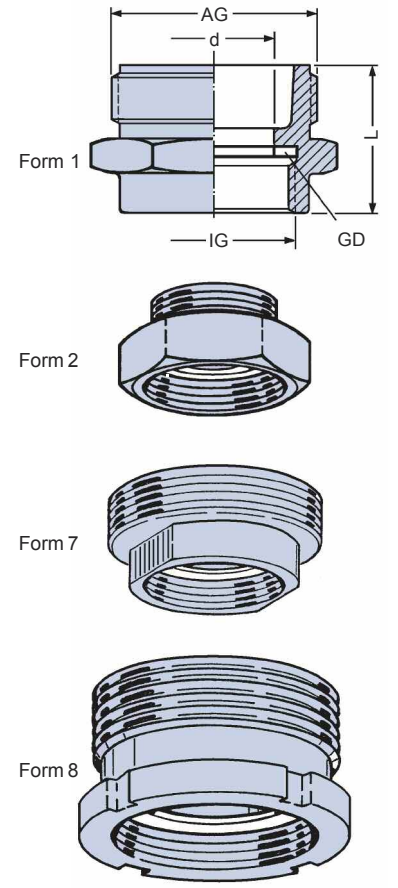

Eisenbahn - Kesselwagengewinde nach DIN 6602 (alte DIN 11)
1) Thread for rail tankers according to DIN 6602 (old DIN 11)

Reduzierstücke Type **RS**, Übergang von Lebensmittelanschluss nach DIN 11851 auf Rohrgewinde DIN EN ISO 228.
Reducers type **RS**, transition to foodstuffs connection according to DIN 11851 to pipe thread acc. to DIN EN ISO 228.

Type **RS** mit Rund-
Außengewinde
nach DIN 405

Type **RS** with male
knuckle thread
acc. to DIN 405

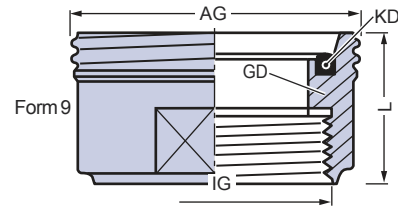

Type **RS** mit Rund-
Innengewinde
nach DIN 405

Type **RS** with female
knuckle thread
acc. to DIN 405

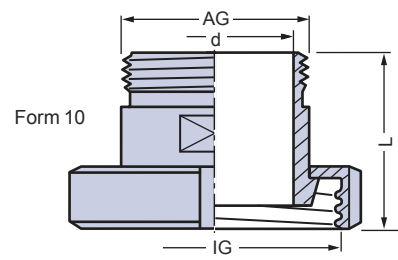

MEDIEN, MEDIENGRUPPEN Wenn nicht anders angegeben, bei Raumtemperatur. Bei Gemischen alle Komponenten beachten!	Messing brass, bronze Ms	Aluminium aluminium Alu	Stahl St. 37 carbon steel St	Edelstahl 1.4571 stainl. steel 316 Ti SS	mit Beschichtung Teflon®/PPA Cover SSE	Polyamid polyamide P (PA)	Polypropylen polypropylene PP
Aliphatische Kohlenwasserstoffe wie Benzin, Diesel, Öle, Petroleum <i>Aliphatic hydrocarbons as gasoline, diesel, fuel oil, crude oil, petroleum</i>	A	A	A	A	A	A	C
Otto - Kraftstoffe mit Aromaten-, Ether-, Methanolzusätzen nach DIN <i>Gasoline with aromatic-, ether- and methanol additives</i>	A	A	A	A	A	A	C
Aromatische Kohlenwasserstoffe wie Benzol, Toluol, Xylol <i>Aromatic hydrocarbons as benzene, toluol, xylol</i>	A	A	A	A	A	A	C
Chlorierte Kohlenwasserst. wie Methylenchlorid, Per- und Trichlorethylen <i>Chlorinated hydrocarbons as methylene-chloride, per- and tri-chloroethylene</i>	A	(A)	A	A	A	A	C
Alkohole wie Ethanol, Butanol, Methanol, Isopropylalkohol <i>Alcohols as ethanol, butanol, methanol, isopropyl alcohol</i>	A	A	A	A	A	A	B
Amine wie Anilin, Butylamin, Pyridin, Diethylamin, Triethylamin <i>Amines as aniline, buthyl amine, pyridine, diethyl amine, triethyl amine</i>	A	A	A	A	A		B
Acetate, Aldehyde, Ester, Ether <i>Acetates, aldehydes, ester, ether</i>	A	A	A	A	A	A-B	B
Ketone wie Aceton, Methyl ethyl keton (MEK), Cyclohexanon <i>Ketones as acetone, methyl ethyl ketone, cyclohexanon</i>	A	A	A	A	A	A	B
Glykole, Enteisungsflüssigkeiten, Frostschutzmittel, Glysantin <i>Glycol, defrosting fluids, anti-freezing fluids</i>	A	B	A	A	A	A	A
Wasser, Abwasser, Seewasser, Kühlwasser, auch ölhaltig <i>Water, sewage, seawater, cooling water also containing oil</i>	A	B	B	A	A	A	A
Asphalt, Heibitumen, Teer bis 200° C <i>Asphalt, hot bitumen, tar up to 200° C</i>	A	C	C	A	-	-	C
Teeröle wie Braun- und Steinkohlenteeröl, Kresol, Phenol <i>Tar oils as lignite-tar oil, coal-tar oil, cresol, phenol</i>	A	B	A	A	A	C	C
Sattdampf, gesättigter Nassdampf bis 220° C <i>High pressure wet saturated steam up to 220° C</i>	A	B	B	A	-	-	C
Eisen-III- chlorid, Eisensalze <i>Ferric-III-chloride, ferric salts</i>	C	C	C	C	A	C	A
Ammoniak wässrig, Flüssigdünger <i>Ammonia hydrons, liquid fertilizer</i>	C	B	A	A	A	A	A
Salzlösungen wie Carbonate, Chloride, Nitrate, Phosphate <i>Salt solutions as carbonates, chlorides, nitrates, phosphates</i>	A-B	B-C	B	A	A	A	A
Laugen wie Kalilauge, Natronlauge, Reinigungslaugen 100° C <i>Alkalies as potassium hydroxide, sodium hydroxide, cleaning alkalies up to 100° C</i>	B	C	B	A	A	B	A
Ameisensäure <i>Formic acid</i>	A-B	B	B	A	A	C	A
Chlorsulfonsäure <i>Chlorosulfonic acid</i>	C	C	B	B	A	C	C
Chromsäure <i>Chromic acid</i>	C	C	B	A	A	C	A
Essigsäure <i>Acetic acid</i>	C	C	B	A	A	C	A
Flusäure, Fluorwasserstoffsäure <i>Hydrofluoric acid</i>	C	C	C	C	A	C	A
Oxalsäure <i>Oxalic acid</i>	C	B	C	A	A	B	A
Phosphorsäure <i>Phosphoric acid</i>	C	C	C	A	A	C	A
Salpetersäure <i>Nitric acid</i>	→ 30 % C 30 - 70 % C 70 - 90 % C	C C B	C C C	A A A	A A A	C C C	A C C
Salzsäure <i>Hydrochloric acid</i>	C	C	C	C	A	C	A
Schwefelsäure <i>Sulfuric acid</i>	→ 65 % C 65 - 95 % C 96 % C	C C B	C C A	B-C B A	A A A	C C C	A A A

- A** = gut geeignet
good, fluid has little or no effect
- B** = bedingt geeignet (z.B. Korrosion, Rost, Abtrag, Quellung)
fair, fluid has minor effect (corrosion, rust, erosion, swelling)
- C** = nicht geeignet
not suitable

VORBEHALT: Eine Garantie für diese allgemeinen Informations-Angaben wird nicht übernommen. Sie wurden den Druckschriften der Rohstoffhersteller entnommen. Zu beachten ist, dass sich die Angaben nur auf reine Werkstoffe beziehen. Spezielle Beständigkeitsversuche können nach Vereinbarung durchgeführt werden.

RESERVATION: The validity of these general information data cannot be guaranteed. The data have been taken from publications of various manufacturers. Please note, that the data refer to pure materials only. Special resistance tests can be made on request.

In Zweifelsfällen bitte rückfragen · In Case of Doubt Please Ask for Information