

GRUPPE 2 Section	GE- WICHT Weight Approx.	SCHLAUCH- GRÖSSE Hose Size		FLANSCH NENNWEITE Flange Diam. Nominal	FLANSCHNORM NENNDRUCK Flange Standard Pressure Nominal	FLANSCH FORM Flange Style	BESTELL- NUMMER Part Number
	≈ kg	ID mm	OD mm	mm/in.	bar *)	Form	Type



TECHNISCHE ÄNDERUNGEN VORBEHALTEN - NACHDRUCK UND KOPIEN NUR MIT UNSEREM EINVERSTÄNDNIS - Specifications subject to change without notice - Copyright ELAFLEX

2,1	25	36 - 38	DN 25	DIN PN 40 (PN 10, 16, 25, 40)	S	SFX 25.40
1,8					F	FFX 25.40
2,9	32	43 - 45	DN 32	DIN PN 40 (PN 10, 16, 25, 40)	S	SFX 32.40
2,5					F	FFX 32.40
2,9	38	50 - 52	DN 40	DIN PN 40 (PN 10, 16, 25, 40)	S	SFX 38.40
2,8					F	FFX 38.40
2,8	40	53 - 55	DN 40	DIN PN 40 (PN 10, 16, 25, 40)	S	SFX 40.40
2,4					F	FFX 40.40
3,4	50	63 - 67	DN 50	DIN PN 16 (PN 10, 16)	S	SFX 50.16
3,1					F	FFX 50.16
4,0					S	SFX 50.40
3,4					F	FFX 50.40
4,3	63	78 - 81	DN 65	DIN PN 16 (PN 10, 16)	S	SFX 63.16
3,8					F	FFX 63.16
4,6					S	SFX 63.40
4,1					F	FFX 63.40
5,4	75	89 - 92	DN 80	DIN PN 16 (PN 10, 16)	S	SFX 75.16
4,6					F	FFX 75.16
6,0					S	SFX 75.40
4,8					F	FFX 75.40
7,1	100	115 - 118	DN 100	DIN PN 16 (PN 10, 16)	S	SFX 100.16
6,5					F	FFX 100.16
8,0					S	SFX 100.40
6,6					F	FFX 100.40
0,9	50	63 - 67	DN 50	TW 1 - 10 bar DIN 28459	S	SFX 50 TW
0,8					F	(FFX 50 TW)
1,1	63	78 - 81	DN 65	TW 1 - 10 bar DIN 28459	S	SFX 63 TW
1,0					F	(FFX 63 TW)
1,3	75	89 - 92	DN 80	TW 1 - 10 bar DIN 28459	S	SFX 75 TW
1,2					F	(FFX 75 TW)
1,7	100	115 - 118	DN 100	TW 3 - 10 bar DIN 28459	S	SFX 100 TW
1,6					F	(FFX 100 TW)
1,0	50	63 - 67	DN 50	TW 1 - 10 bar DIN 28459	S	SFC 50 TW
0,9					F	(FFC 50 TW)
1,2	63	78 - 82	DN 65	TW 1 - 10 bar DIN 28459	S	SFC 63 TW
1,1					F	(FFC 63 TW)
1,4	75	94 - 97	DN 80	TW 1 - 10 bar DIN 28459	S	SFC 75 TW
1,3					F	(FFC 75 TW)
2,2	100	114 - 119	DN 100	TW 3 - 10 bar DIN 28459	S	SFC100 TW
2,0					F	(FFC 100 TW)
0,9	100	114 - 119	DN 100	TTMA - 10 bar	F	FFC 100-4" TTMA
6,0	125	143 - 147	DN 125	TW 5 - 10 bar DIN 28459	S	SFC 125 TW
5,7					F	(FFC 125 TW)
8,5	150	167 - 173	DN 150	TW 7 - 10 bar DIN 28459	S	SFC 150 TW
8,1					F	(FFC 150 TW)

Schlauchflansche nach EN 14420-4 aus Stahl verzinkt und chromatiert mit SPANNFIX -Einband aus Aluminium. Flansche nach EN 1092-1. Verwendungsbereich, Werkstoffe und Betriebsdruck siehe Seite 271.

Flanged hose couplings according to EN 14420-4 of steel, zinc plated and chromated with SPANNFIX safety clamps of aluminium. Flanges acc. to EN 1092-1. Range of application, materials and working pressure as described on page 271.

Losser Flansch, drehbar, und Schlauchstutzen aus Stahl Zn Cr

FORM S

Swiveling flange (lap joint flange) and hose tail of steel Zn Cr

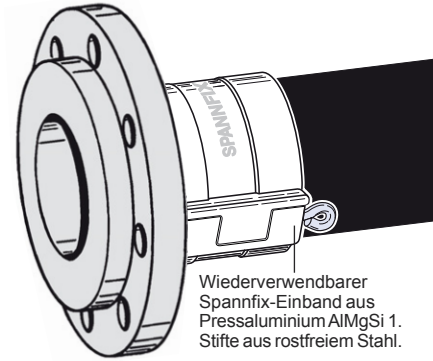

Wiederverwendbarer Spannfix-Einband aus Pressaluminium AlMgSi 1. Stifte aus rostfreiem Stahl.

Re-usable pinned clamps of hot stamped aluminium. Pins of stainless steel.

Fester Flansch mit Schlauchstutzen aus Stahl Zn Cr

FORM F

Fixed flange and hose tail of steel Zn Cr

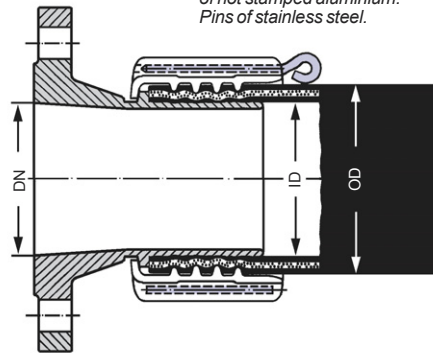

TW-Flansch Schlauchstutzen und Spannfix aus Aluminium Betriebsdruck PN 10

"TW"-Flange (Tank Truck), hose tail and Spannfix clamps of aluminium.

Work. pressure up to 10 bar

Type TW

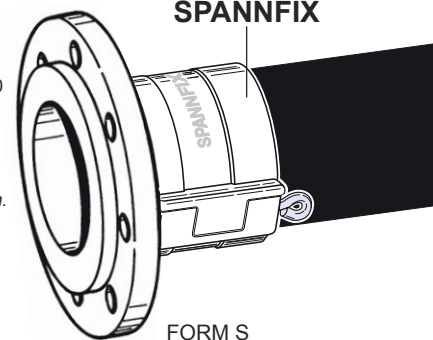

TW-Flansch Schlauchstutzen und Spannloc aus Aluminium Betriebsdruck PN 10

"TW"-Flange, (Tank Truck) hose tail and Spannloc clamps of aluminium.

Work. pressure up to 10 bar

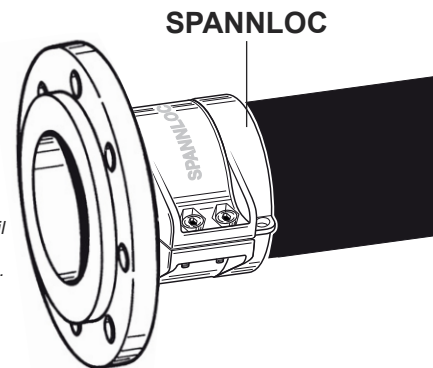

*) Flanschmaße siehe Seite 278 - Flange measurements see page 278

Gebräuchliche Maße für Schlauchflansche • Measurements for Hose Flanges

NENNWEITE <i>Diameter Nominal</i>	AUSSEN-Ø <i>Outside Diameter</i>		DICHTFLÄCHE <i>Sealing Surface</i>		LOCHKREIS <i>Bolt Circle</i>		SCHRAUBENLÖCHER <i>Bolt Holes</i>			FLANSCHNORM <i>Flange Standard</i>
	D		g Ø		k Ø		Anzahl No.	l Ø		
	mm	in.	mm	in.	mm	in.		mm	in.	
15 (1/2")	95		45		65		4	14		DIN PN 40
	88,9	3 1/2"	34,9	1 3/8"	60,3	2 3/8"	4	15,9	5/8"	ASA 150
	95,3	3 3/4"	34,9	1 3/8"	66,7	2 3/8"	4	15,9	5/8"	ASA 300
20 (3/4")	105		58		75		4	14		DIN PN 40
	98,4	3 7/8"	42,9	1 11/16"	69,9	2 3/4"	4	15,9	5/8"	ASA 150
	117,5	4 5/8"	42,9	1 11/16"	82,5	3 1/4"	4	19	3/4"	ASA 300
25 (1")	115		68		85		4	14		DIN PN 40
	108	4 1/4"	50,8	2"	79,4	3 1/8"	4	15,9	5/8"	ASA 150
	123,8	4 7/8"	50,8	2"	88,9	3 1/2"	4	19	3/4"	ASA 300
32 (1 1/4")	140		78		100		4	18		DIN PN 40
	117,5	4 5/8"	63,5	2 1/2"	88,9	3 1/2"	4	15,9	5/8"	ASA 150
	133,4	5 1/4"	63,5	2 1/2"	98,4	3 7/8"	4	19	3/4"	ASA 300
40 (1 1/2")	150		88		110		4	18		DIN PN 40
	127	5"	73	2 7/8"	98,4	3 7/8"	4	15,9	5/8"	ASA 150
	155,6	6 1/8"	73	2 7/8"	114,3	4 1/2"	4	22,2	7/8"	ASA 300
50 (2")	140		90		110		4	14		DIN PN 6 (nur/only Form F)
	165		102		125		4	18		DIN PN 16
	165		102		125		4	18		DIN PN 40
	152,4	6"	92,1	3 5/8"	120,7	4 3/4"	4	19	3/4"	ASA 150
	165,1	6 1/2"	92,1	3 5/8"	127	5"	8	19	3/4"	ASA 300
65 (2 1/2")	160		110		130		4	14		DIN PN 6 (nur/only Form F)
	185		122		145		4	18		DIN PN 16
	185		122		145		8 (4)*	18		DIN PN 40
	177,8	7"	104,8	4 1/8"	139,7	5 1/2"	4	19	3/4"	ASA 150
	190,5	7 1/2"	104,8	4 1/8"	149,2	5 7/8"	8	22,2	7/8"	ASA 300
80 (3")	154				130		8	11		TW 1 DIN 28459
	190		128		150		4	18		DIN PN 6 (nur/only Form F)
	200		138		160		8	18		DIN PN 16
	200		138		160		8	18		DIN PN 40
	190,5	7 1/2"	127	5"	152,4	6"	4	19	3/4"	ASA 150
	209,6	8 1/4"	127	5"	168,3	6 5/8"	8	22,2	5/8"	ASA 300
100 (4")	168,3	6 5/8"	138		149,2	5 7/8"	8	11,1	7/16"	TTMA RP No.28-09
	174				150		8	14		TW 3 DIN 28459
	210		148		170		4	18		DIN PN 6 (nur/only Form F)
	220		158		180		8	18		DIN PN 16
	235		162		190		8	22		DIN PN 40
	228,6	9"	157,2	6 3/16"	190,5	7 1/2"	8	19	3/4"	ASA 150
	254	10"	157,2	6 3/16"	200	7 7/8"	8	22,2	7/8"	ASA 300
125 (5")	204				176		8	14		TW 5 DIN 28459
	240		178		200		8	18		DIN PN 6 (nur/only Form F)
	250		188		210		8	18		DIN PN 16
	270		188		220		8	26		DIN PN 25
	254	10"	185,7	7 5/16"	215,9	8 1/2"	8	22,2	7/8"	ASA 150
	279,4	11"	185,7	7 5/16"	235	9 1/4"	8	22,2	7/8"	ASA 300
150 (6")	240				210		12	14		TW 7 DIN 28459
	265		202		225		8	18		DIN PN 6 (nur/only Form F)
	285		212		240		8	22		DIN PN 16
	300		218		250		8	26		DIN PN 40
	279,4	11"	215,9	8 1/2"	241,3	9 1/2"	8	22,2	7/8"	ASA 150
	317,5	12 1/2"	215,9	8 1/2"	269,9	10 5/8"	12	22,2	7/8"	ASA 300
200 (8")	320		258		280		8	18		DIN PN 6
	340		268		295		8	22		DIN PN 10
	340		268		295		12	22		DIN PN 16
	360		278		310		12	26		DIN PN 25
	375		285		320		12	30		DIN PN 40
	342,9	13 1/2"	269,9	10 5/8"	298,5	11 3/4"	8	22,2	7/8"	ASA 150
	381	15"	269,9	10 5/8"	330,2	13"	12	25,4	1"	ASA 300

Diese Tabelle enthält die Maße der für Schlauchflansche üblichen Normen. Bitte beachten: DIN 2633 und DIN 2673 wurden durch EN 1092-1:2002 ersetzt. Flansche nach anderen Normen - z. B. BS oder NF - können auf Wunsch geliefert werden.

The chart shows the measures of the customary standards for flanged hose fittings. Please note: DIN 2633 and DIN 2673 have been replaced by EN 1092-1:2002.

Flanges to other standards, e.g. BS or NF, available on request.

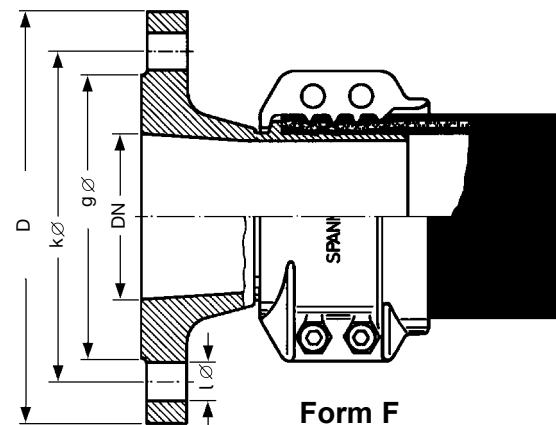
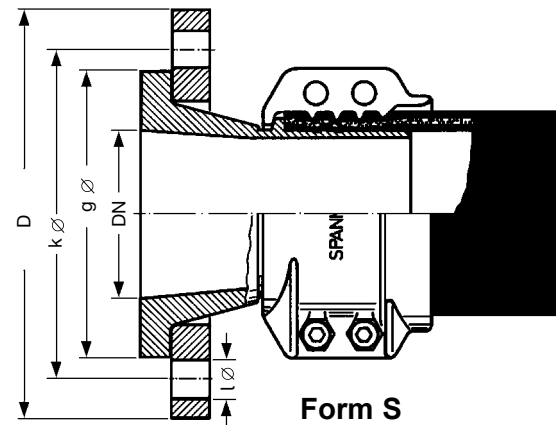
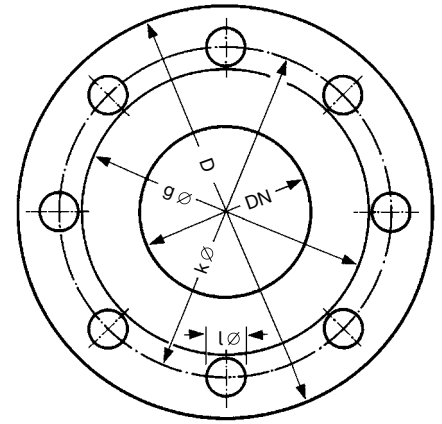

Nach EN 1092-1 Standard mit 8 Löchern, mit 4 Löchern auf Anfrage

*) According to EN 1092-1 with 8 holes as standard, with 4 holes on request